

# ZEVO MAX II

BY OPTICLIMATE

## Water Cooler Manual



# Table of Contents

<b>1. SAFETY</b>	<b>2</b>
<b>1.1 SAFETY PRECAUTIONS</b>	<b>2</b>
<b>2. SPECIFICATIONS</b>	<b>3</b>
<b>2.1 INTRODUCTION</b>	<b>3</b>
<b>2.2 SPECIFICATIONS</b>	<b>3</b>
<b>2.3 WATERCONNECTIONS</b>	<b>3</b>
<b>2.4 3RD PARTY - WHAT TO BUY</b>	<b>4</b>
<b>2.5 MULTIPLE REVOMAXII UNITS, SINGLE COOLER</b>	<b>4</b>
<b>2.6 TICHELMANN PRINCIPLE</b>	<b>4</b>
<b>2.7 SPECIAL CONFIGURATIONS</b>	<b>5</b>
<b>3. PLACEMENT</b>	<b>6</b>
<b>3.1 WATER COOLER PLACEMENT</b>	<b>6</b>
<b>3.2 MOUNTING</b>	<b>6</b>
<b>4. WATER CIRCULATION</b>	<b>7</b>
<b>4.1 WATER PUMP</b>	<b>7</b>
<b>4.2 AIR &amp; PRESSURE</b>	<b>7</b>
<b>4.3 WATER TEMPERATURE</b>	<b>7</b>
<b>4.4 WATER IN, WATER OUT</b>	<b>7</b>
<b>4.5 WATER FLOW</b>	<b>8</b>
<b>5. CONTROL SENSOR</b>	<b>9</b>
<b>5.1 START/STOP</b>	<b>9</b>
<b>5.2 DAILY OPERATION &amp; CONTROL</b>	<b>9</b>
<b>5.3 BASIC CONTROLLED</b>	<b>9</b>
<b>5.4 INVERTER CONTROLLED</b>	<b>9</b>
<b>6. BUILDING A CLOSED LOOP</b>	<b>10</b>
<b>6.1 WATER COOLER</b>	<b>10</b>
<b>6.2 STEPS TO CREATE A CLOSED LOOP</b>	<b>10</b>
<b>6.3 CONNECTION DIAGRAM</b>	<b>12</b>
<b>6.4 BASIC CONTROLLED - CLOSED LOOP</b>	<b>13</b>
<b>6.5 BASIC CONTROLLED - CLOSED LOOP - FIRST USE</b>	<b>15</b>
<b>6.6 INVERTER CONTROLLED - CLOSED LOOP - FIRST USE</b>	<b>18</b>
<b>7. FILLING THE LOOP</b>	<b>19</b>
<b>7.1 GLYCOL</b>	<b>19</b>
<b>7.2 FILLING THE LOOP</b>	<b>19</b>
<b>7.3 START USING</b>	<b>19</b>
<b>8. WARRANTY WARRANTY</b>	<b>20</b>

# 1. SAFETY



## CAUTION

Please read this manual carefully before attempting to install the Opticlimate Revomax II or Pro3/4 system with water cooler. Opticlimate delivers high performance climate control system, we strongly advice to seek the services of an installation professional.

These products may represent a possible shock or fire hazard if improperly installed or attached in any way. Products should be installed in accordance with the owners manual and local electrical guidelines and law.

**When operating with a seperate humidifier, make sure that it is connected to a reverse osmosis filter or scale filer. Fan faults caused by lime deposits are not covered under our warranty.**

## 1.1 SAFETY PRECAUTIONS

### Installation

- Make sure the Revomax is installed spirit level, the Pro3/4 models need a 1 cm slope front to back for condensation water to run off.
- Make sure the water cooler is installed outside, fastened and secure with enough room to dissipate heated air.
- Make sure the water pump is installed fastened, secure and spirit leveled.

### Electricity

- Make sure the room temperature sensor is connected on the correct position on the circuit-board.
- Make sure the room temperature sensor is in the room and shielded from direct light or air streams.

### Water/glycol

- Make sure flow and return piping has the correct diameter, (chapter 4.6) for more information.
- Make sure there is no air trapped in the system. Use an air vent at the hight point of the circuit (chapter 6).
- Use water/glycol mix for below zero temperature protection (chapter 7).

### General

- Keep distance from the fan / supply air. Turning parts and rotating fan blades are dangerous.
- Do not power the machine when the electric compartment is open, circuit-boards and connectors might be charged.
- In a food / agro environment always use food-grade glycol (propylene glycol) (closed loop only, chapter 7).
- Make sure you are aware of all features and settings for correct day-to-day operation.
- Electrical connections should be done by a certified electrician. In some regions this is required by law.
- Water glycol setup should be done by a certified installer. In some regions this is required by law.
- Operating the system should be done by personnel that is fully aware of it's functions.
- Do not operate the unit without the filter or with a less effective filter. The heat exchange coils inside the unit become clogged and require disassembly to clean.

# 2. SPECIFICATIONS

## 2.1 INTRODUCTION

When building a RevomaxII or Pro3/Pro4 closed-loop system, the key component is the water cooler to cool the water that was heated by the RevomaxII or Pro3/Pro4. The more cooling power required in the room, the higher the output water temperature of the system, which then needs to be reduced again before the loop restarts.

As a general rule of thumb, you need 1 kW of cooling power for every 1 kW generated by the RevomaxII or Pro3/Pro4. This is not an exact science, as every system and environment can vary dramatically. More cooling capacity is always fine, too little and the performance might not reach the level you desire. More information on this topic is in chapter 6.1. Always contact a dealer or reach out to us at [airluxtechnologies.com](http://airluxtechnologies.com) for advice.

To accommodate all different types of installations we have three types of water coolers:

- Compact Ultra Light - Lightweight and compact option to accommodate limited spaces
- Industrial - Heavy duty, high performing and most common option, perfect for most installations
- Industrial Horizontal - Industrial model but with upward facing fans. Used when there is limited space for heated air to dissipate sideways.



Compact



Industrial



Industrial Horizontal

## 2.2 SPECIFICATIONS

MODEL	Weight	Dimension LxHxD	Sound-level	Power	Fans	Fan diameter	Volume
Water Cooler 4.5 kW Compact	7 kg	650 x 410 x 320 mm	28 dB(A)	0.06 kW	1	350 mm	2 ltr
Water Cooler 9 kW Compact	13 kg	1200 x 410 x 320 mm	31 dB(A)	0.12 kW	2	350 mm	4 ltr
Water Cooler 14 kW Compact	19 kg	1750 x 410 x 320 mm	33 dB(A)	0,18 kW	3	350 mm	6 ltr
Water Cooler 18 kW Compact	26 kg	1200 x 810 x 320 mm	34 dB(A)	0,24 kW	2	350 mm	8 ltr
Water Cooler 32 kW Compact	52 kg	1750 x 810 x 320 mm	36 dB(A)	0.36 kW	6	350 mm	21 ltr
Water Cooler 12 kW Industrial	63 kg	1025 x 933 x 600 mm	32 dB(A)	0.27 kW	1	500 mm	6 ltr
Water Cooler 17 kW Industrial	76 kg	1025 x 933 x 600 mm	32dB(A)	0.27 kW	1	500 mm	11 ltr
Water Cooler 32 kW Industrial	125 kg	1600 x 983 x 600 mm	40 dB(A)	0.60 kW	1	630 mm	19 ltr
Water Cooler 32 kW Horizontal	125 kg	1600 x 983 x 600 mm	36 dB(A)	0.36 kW	6	350 mm	21 ltr

## 2.3 WATERCONNECTIONS

All models come with appropriate sized threaded water connections to make sure there is enough water flow to cool the system. All connectors on the water cooler are male threaded. Note: this does not represent the needed piping diameter. Check chapter 2.4 for more information on piping diameter.

	IN	OUT
Water cooler 4.5 kW Compact Ultra Light	1/2"	1/2"
Water cooler 9 kW Compact Ultra Light	3/4"	3/4"
Water cooler 14 kW Compact Ultra Light	3/4"	3/4"
Water cooler 18 kW Compact Ultra Light	1"	1"
Water cooler 32 kW Compact Ultra Light	1"1/4	1"1/4
Water cooler 12 kW Industrial Grade	3/4"	3/4"
Water cooler 17 kW Industrial Grade	1"	1"
Water cooler 32 kW Industrial Grade	1"1/4	1"1/4
Water cooler 32 kW Industrial Grade - Horizontal	1"1/4	1"1/4

## 2.4 3RD PARTY - WHAT TO BUY

To connect all piping and sensors to your system, you also need a list of water connections and accessories that fit your piping of choice. We have a comprehensive list of needed items on our knowledgebase at <https://opticlimate.com/knowledge-base/> in the checklist section.

## 2.5 MULTIPLE REVOMAXII UNITS, SINGLE COOLER

For efficiency purposes you are able to install multiple RevomaxII or Pro units on a single cooler in a single closed loop. As long as the watercooler has sufficient cooling capacity to cool the combined heated water generated by the RevomaxII units. Always use identical models in a single loop.

The drawing below is conceptual for readability purposes. Note that the actual length of the piping must be the exact length for each model to make sure the cooling works properly.

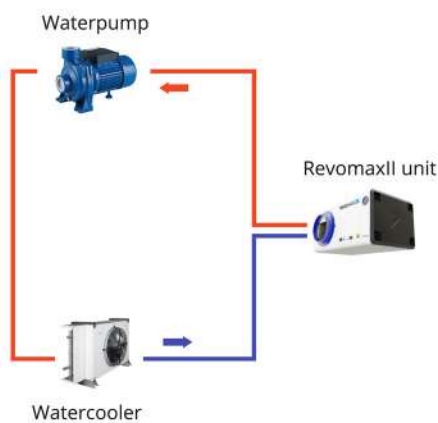

Normal 1-1 setup

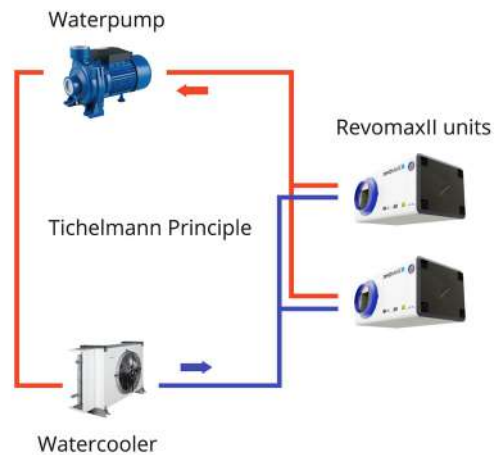

Conceptual drawing of the Tichelmann principle

## 2.6 TICHELMANN PRINCIPLE

The Tichelmann principle is a simple method used to make sure water flows evenly through several connected devices, like coolers or radiators. It works by designing the pipes so that every device has the same total pipe length — the distance the water travels to and from each unit. The first device in the line has a short supply and a long return, while the last one has a long supply and a short return. Because the total path is equal for all, the water pressure and flow are balanced automatically. This means every unit gets the same amount of cooling or heating water, resulting in stable performance and efficient operation.

## 2.7 SPECIAL CONFIGURATIONS

Besides the basic options, take a brief look at what we can do with the RevomaxII and Pro models. All variations are perfectly viable and scalable and need a professional design and preparation from your dealer or find us at [airluxtechnologies.com](http://airluxtechnologies.com). The high-performing RevomaxII system needs to be installed with all hardware and guidelines (chapter 2.1) in mind to ensure long-term reliable operation.

### Multi-RevomaxII setup with single cooler

Install two or more RevomaxII or Pro units in multiple growing areas or rooms, combined with one big watercooler unit. The Tichelmann principle applies as described in previous page.



### Multi-RevomaxII setup with multiple coolers

Install multiple RevomaxII or Pro units in multiple growing areas combined with multiple watercoolers. The Tichelmann principle applies as described in previous page. Always consult a professional before designing a multi to multi setup.

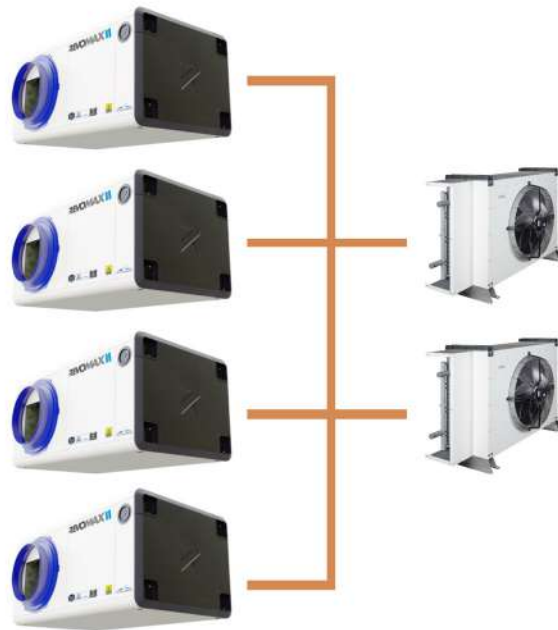

# 3. PLACEMENT

## 3.1 WATER COOLER PLACEMENT

A watercooler needs room to suck air into its fans and dispatch the air on the other side. To provide the watercooler with sufficient free air to use for cooling, the watercooler needs to be placed outdoors and with sufficient room to operate.

We recommend, when possible, to place the watercooler outside of direct sunlight for best performance. Also, in snowy and sandy areas it's extremely important to keep the in- and outlet free of obstacles during operation. Build a roof or shelter to protect the watercoolers in- and outlet and/or direct sunlight.

Opticlimate has two main types of watercoolers in its range. There are compact models and industrial grade models. For most situations the Industrial models are the best fit. For limited spaces we have compact models available as well.

To ensure proper heat dissipation, the water cooler requires a minimum of 3 meters of unobstructed space in front of the unit. This clearance allows for adequate airflow, which can extend up to 50 meters. It is essential to ensure that the heated air can freely exit the area without obstruction.

In situations where there is insufficient horizontal space for effective airflow dissipation, we offer a vertical discharge model (Industrial Horizontal). This unit redirects airflow upwards rather than sideways, eliminating the requirement for horizontal clearance.

Use the guidelines below to ensure proper operation.

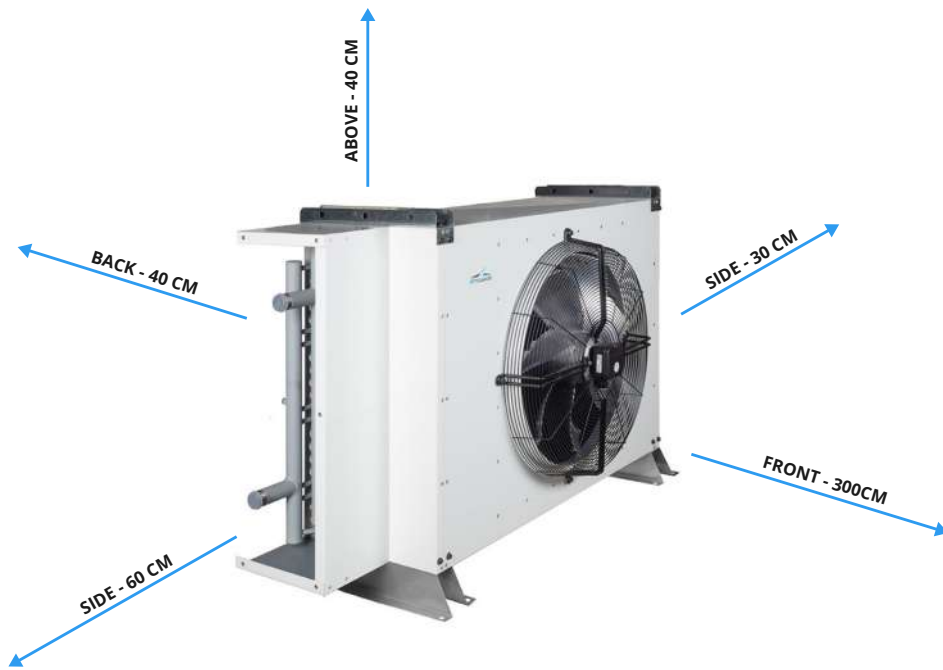

## 3.2 MOUNTING

The water cooler is supplied with standard floor-standing mounts and must always be installed in a fixed position. Use the supplied floor stand or design your own secure mounting solution to ensure the cooler is firmly anchored. A stable installation minimizes stress on the piping and fittings, making the water connections more reliable and less prone to leakage.

# 4. WATER CIRCULATION

## 4.1 WATER PUMP

To circulate the water in the loop, we need to add a water pump. The pump determines the water flow in your system and can be controlled in two distinct ways:

- Basic Controlled: on/off, controlled by a smart 230v port
- Inverter Controlled: stepless, controlled by inverters

Both the RevomaxII and Pro models have access to these options. The inverters can seamlessly in- and decrease it's speed and waterflow depending on your needs. This means in practice much better control and stable climate for your crops.

All water coolers come with a pump with sufficient circulation power. When ordering your water cooler you need to choose if you need a basic or inverter controlled system. This determines if you receive a single phase 230v or triple phase 400v version of the pump.

## 4.2 AIR & PRESSURE

The goal is to create a loop with no or very little air left in the system. The less air, the better performance and sensor readings. To achieve this goal we'll need to install an air bleeder and a pressure release valve. In chapter 6 we'll go in depth on how and where to install these elements.

## 4.3 WATER TEMPERATURE

It is important to note that the operating temperature of the RevomaxII and Pro3/4 models differ slightly and must be adjusted accordingly. The controller by default is programmed for the RevomaxII operating temperature of 32 degrees Celcius. When you use a Pro3/4 model please set the temperature to 29 degrees Celcius. Refer to the included Smartbox manual for instructions or contact us at [airluxtechnologies.com](http://airluxtechnologies.com).

## 4.4 WATER IN, WATER OUT

It is important you'll install the climate system (Pro or Revomax), the water cooler and water pump in the correct order and use the designated IN and OUT ports of the respective components. All elements have markings on the unit and and/or respective manuals. When not connected in the correct order and ports, the system will not function properly or not at all.

Note: While the RevomaxII has a water in and a water out for setting up the unit in a closed loop, the Pro3 and Pro4 also have a Bypass connection. When installing the Pro3/4 in a closed loop with water cooler, remove the stop from the bypass and install it to the water outlet. Now use the Bypass for outputting the waterflow back to the water pump.

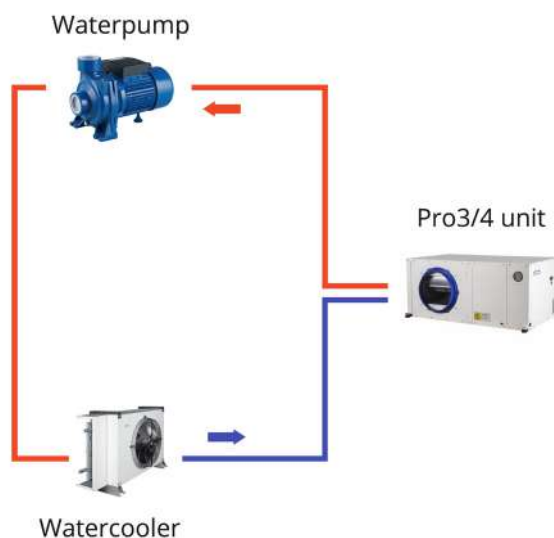

*RevomaxII Backside:  
water connections*

1. Water Outlet
2. Water Inlet
3. Condensation Outlet

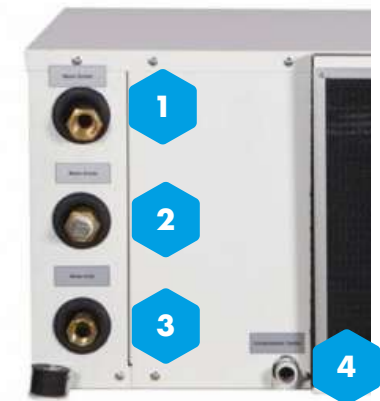

*Pro 3/4 Backside:  
water connections*

1. Water Outlet
2. Water Bypass
3. Water Inlet
4. Condensation Outlet

## 4.5 WATER FLOW

For the water cooler to cool the water properly, good water flow is essential. This means the water must be circulated in a certain speed and certain pressure. As we've learned earlier, piping is the main factor to decide water flow is good. When the flow is not optimal the system cannot cool and the opticlimate unit will not operate to specification which can lead to poor results. Make sure to use smooth piping, proper diameter, reduce bends as much as possible and keep filters/strainers clean.

## 4.6 PIPING & DIAMETER

Piping is not included in the RevomaxII package as every situation is different. The system can be connected with industry-standard PE Tyleen or other type of water piping. We recommend using piping with 'quick-connectors' for easy and flexible installation. A great alternative is to use PVC-C. We recommend using a certified plumber for the installation of the loop.

To determine the correct piping diameter for your setup, two key factors must be considered: length and complexity. We always recommend keeping the loop as short and straightforward as possible, since every bend and every additional meter reduces water flow.

There is no universal rule, as every installation differs. As a general guideline, use 32 mm piping for shorter loops with few bends, and 40 mm or more when length and complexity increase. Contact your dealer or a certified professional for advice.



# 5. CONTROL SENSOR

## 5.1 START/STOP

The first thing we need to do is connect the Pro3, Pro4 or RevomaxII to a start/stop sensor. This sensor is the main communication between the unit and the control setup (Smartbox) in either basic or inverter option. For detailed information on the connection boards, please refer to our extensive RevomaxII and Pro3/4 manuals.

Both model ranges have a front panel to cover the controlboard and connections. Check their respective manuals for detailed information.

Both the Pro3/4 and RevomaxII have the same control setup with the main exception being the start-stop sensor. All control here-after is the same for both models. For detailed instructions refer to our RevomaxII or Pro3/4 manual.



### RevomaxII sensor



### Pro3 Pro4 sensor



## 5.2 DAILY OPERATION & CONTROL

For controlling the RevomaxII or Pro 3/4 we refer to the respective manuals. The installation and configuration of the controllers is not part of this manual.

Check our knowledgebase at [opticlimate.com/knowledge-base/](http://opticlimate.com/knowledge-base/) to find everything you need to install your setup.

# 6. BUILDING A CLOSED LOOP

## 6.1 WATER COOLER

Both the RevomaxII and Pro models share the same setup for a closed loop system. For readability purposes the following chapter is written for the RevomaxII model but the same instructions apply unless stated otherwise in a particular section. As stated earlier, make sure to use the Bypass outlet of the Pro models instead of the regular output. More information in chapter 4.5.



Compact



Industrial



Industrial Horizontal



Drainage tap



Air Bleeder



Tapsaddle

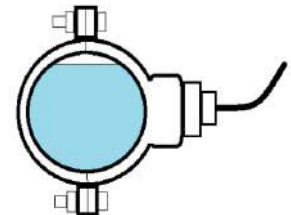

Tapsaddle side-view

## 6.2 STEPS TO CREATE A CLOSED LOOP

After determining the correct piping diameter (chapter 4.6) and acquiring all 3rd party piping and connectors, we can start building our closed loop system. For reference to all piping diameters check our knowledgebase at <https://opticlimate.com/knowledge-base/> in the checklist section.

For video instructions on all steps, refer to our [airluxtechnologies YouTube channel](#).

### 1. Install the pump, water cooler and RevomaxII

Install the pump, water cooler and RevomaxII in an upright position and make sure all elements are installed spirit leveled. Instructions on placement are in chapter 3.

### 2. Connect the RevomaxII in- and out and air-bleeder

Install connectors from the RevomaxII in- and output to your specified piping diameter. Also install the air-bleeder on the highest point of the installation. Make sure you use teflon in all metal connections and properly glue all PVC-C piping when used.

Optional but highly recommended is to install drainage taps at in- and outlet to be able to shut down water supply to the RevomaxII when needed.

### 3. Connect RevomaxII in to water cooler out

Continue to connect the RevomaxII input to the water cooler output and make sure you install a temperature sensor in this part of the loop. Use a t-connector or tap saddle to install the temperature sensor between the watercooler (out) and RevomaxII (in). Note the water flow direction (orange arrows). Make sure the loop is empty before installing the temperature sensor. We designate the water temperature as OUT because it is installed after the watercooler. Always install sideways to prevent measuring air.

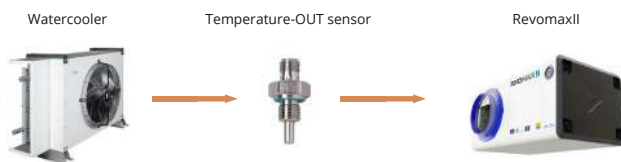

Step 3 install sequence

#### 4. Connect the pump, air separator and two ports

Now connect the air separator to the pump and start to connect the water pump output to the water cooler input. In between we'll install a manometer and the pressure (mandatory for advanced control systems) sensor the same way as the temperature sensor in the previous step. Optionally install a manual valve to shut down water flow when needed.



Step 4 install sequence

#### 5. Complete loop from water pump in to RevomaxII out

The loop is nearly complete. From the water pump in where the Air Separator is connected, lead the loop to the RevomaxII output. Optionally install a manual valve to shut down water flow when needed. Here we need two ports: a manometer, a pressure sensor and an extra temperature sensor in case you want to build an advanced control setup (chapter 6.7).

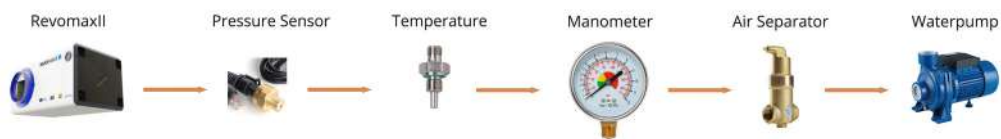

Step 5 install sequence

#### 6. Filling Tap & Optional: Expansion Vessel and Pressure Relief Valve

First make sure to install a filling tap so your loop can be filled later on. The location of the filling tap has no impact of the operation, install it in a convenient location, preferable at a low point to be able to drain the loop. Optionally for more stable operation you can install an expansion vessel and pressure relief valve. When temperature rises, water expands. The vessel compensates for this effect. The vessel must be installed outside the loop.

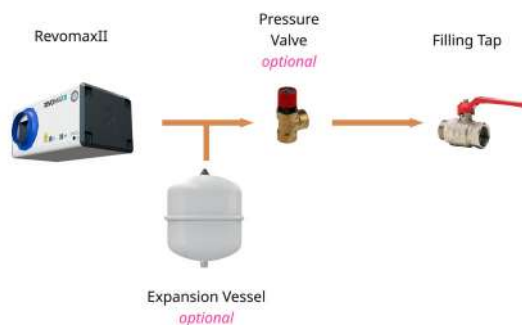

Step 6 install sequence

## 6.3 CONNECTION DIAGRAM

The complete loop now should look like the schematic below, you'll find all the elements in their logical locations. Make sure to install all hardware, sensors, and other components in these exact positions unless stated otherwise.

The following items are optional but recommended:

- Pressure Valve – Releases excess pressure and prevents the loop from building up too much pressure.
- Expansion Vessel – Collects and regulates excess pressure.
- Drain Valve – Allows the water/glycol mix to be drained from the system when needed. Should be installed at the lowest point of the loop.

The following items are mandatory when installing a closed loop with advanced control:

- Temperature Sensor – A second temperature sensor is required when using the advanced control setup.
- Pressure Sensors – Detect current water pressure drops and warns the user to take action to prevent possible damage to the system.

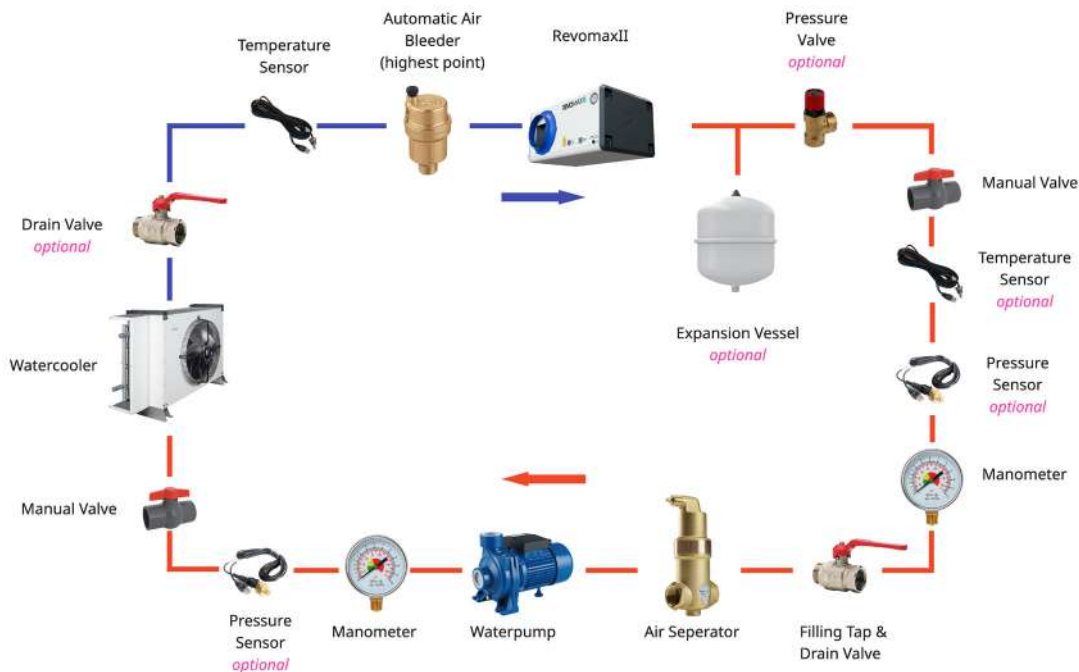

## 6.4 BASIC CONTROLLED - CLOSED LOOP

### Applies to: Basic Closed Loop

The water based elements of the basic closed loop system are now installed and need to be connected to it's central control hardware. For the advanced control setup, skip to chapter 6.7

The basic setup is controlled by a SmartBox 6/3 and controls the water pump and water cooler via a power outlet. You already selected and connected power, and the Smart Remote Controller. For reference we'll recap these steps and add some final steps.

#### 1. Select correct cable and install an MCD and RCD-B

Check the required cable diameter in the specifications and install the power cable, MCD and RCD-B as described in chapter 6.2. Ask a certified electrician to install these elements.

#### 2. Install the correct power cable using

Use the pass-through to install the open-end power cable to the connection board as described in chapter 6.3. Ask a certified electrician to install these elements.

#### 3. Install and connect sensors

Connect the temperature sensor, the one installed in front of the RevomaxII to the P1 port on the SmartBox 6/3. The port is located in the bottom-left of the Smartbox 6/3.

Last part of this step is the compressor start stop sensor. Connect it to position 4 of the connection board (chapter 6.1). Now lead the communication cable to the Smartbox 6/3 and connect it to the in/out port.



P1 port on Smartbox 6/3

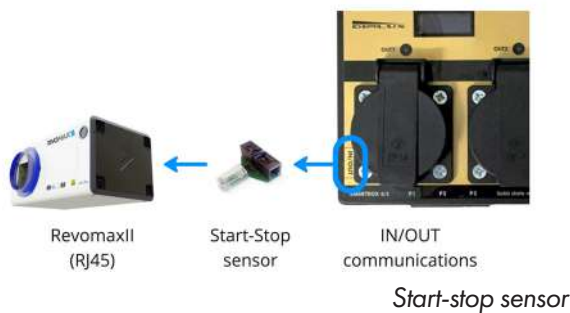

#### 4. Communication cable to Smart Remote Controller

Connect the Smart Remote Controller with the supplied UTP-USB cable as described in chapter 6.4.

#### 5. Connect the water cooler and water pump to the SmartBox 6/3

The last step is to connect the water cooler to the smart 230v power connector port OUT-1 and the water pump to the smart 230v port OUT-3. It is important you use these specific ports as they are pre-configured.

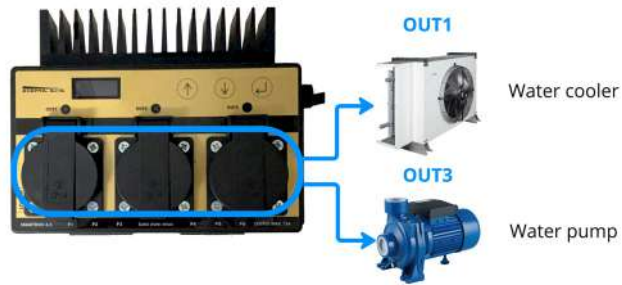

#### Complete control schematic

The complete control schematic now must look like this.

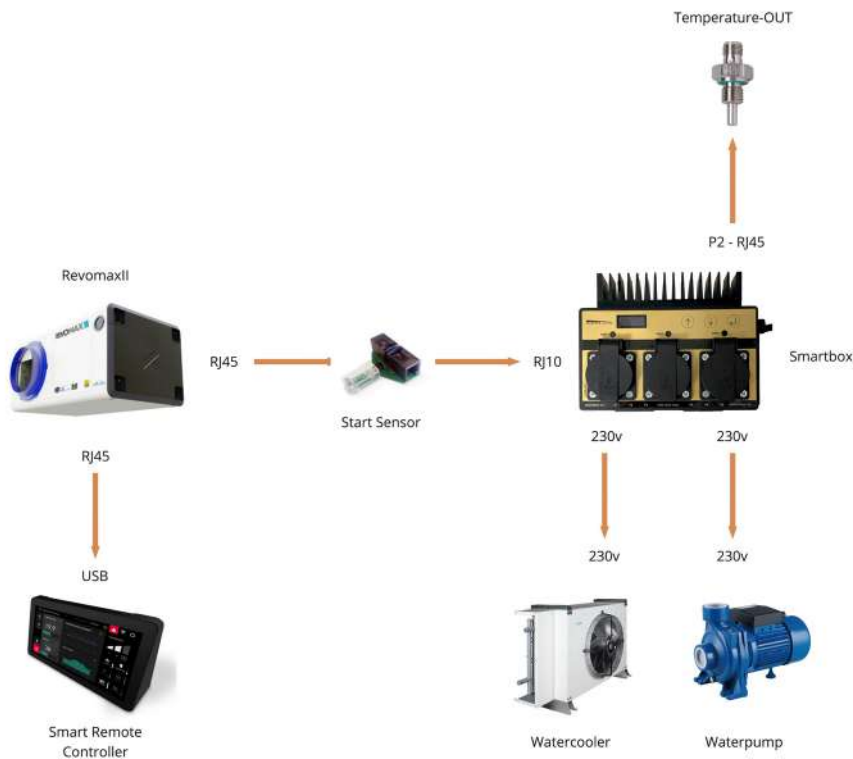

*Basic control setup*

## 6.5 BASIC CONTROLLED - CLOSED LOOP - FIRST USE

Before we can start using the system we first need to check some basic settings. In 6 steps we'll guide you through all steps to get your RevomaxII operational.

### 1. Check essential settings

A few settings need to be checked. First make sure the system is in water cooler mode. Navigate to MENU > SETTINGS > OPTICLIMATE SETTINGS > S.06 and make sure it is set to ON.

The second setting is the internal pressure, which is in the same menu under S.64. Make sure it is set to 23 bar.

### 2. First Run

First use chapter 7 to fill the loop. Now we need to force the RevomaxII into cooling mode. Use heaters and/or fixtures to heat the room to around 25 degrees Celcius and is stable. Now set the RevomaxII to 16 degrees Celcius to force it into cooling mode. The pump and fan should be activated automatically.

### 3. Water pressure and internal valve

The water pressure must be at least 0.5 bar during operation. Add mode water/glycol if the threshold is not met. Now check the internal valve which must be open. Navigate to:

MENU > SETTINGS > OUTPUTS > Q.05 (water valve). The bar must be filled out to 1600 steps.



Water valve control

### 4. Delta Temperature

On the SmartBox 6/3, check the reference temperature which must be set to 32 degrees Celcius. Click UP, ENTER, ENTER and use the UP/DOWN keys to change the temperature if needed.

Now, on the Smart Remote Controller navigate to:  
MENU > SETTINGS > ALL SENSORS

Set target temperatures I:11 to 32 degrees Celcius and I:08 to 37 degrees Celcius. This means the delta (difference) is 5 degrees, which is optimal. Control the delta temperature by changing the water flow.



Water temperature control

- When the delta is too LOW (less than 5 degrees): CLOSE the valve, there is too much flow
- When the delta is too HIGH (more than 5 degrees): OPEN the valve, there is too little flow

Adjust in small increments and wait for the system to respond. This can take a few minutes. After all temperatures are stable for a few hours, adjust the room temperature to the desired temperature.

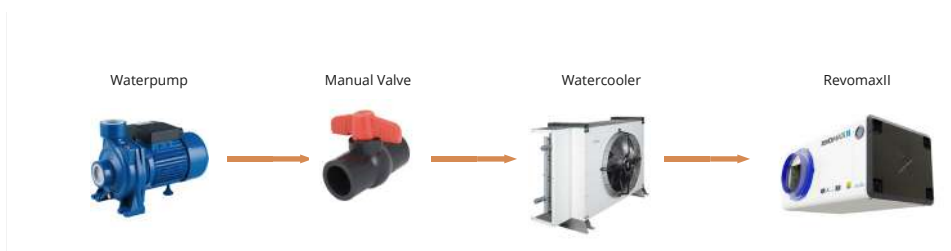

Manual valve install sequence

### 5. Base settings

To make sure the system responds correctly to operating settings like the timer, we need to set the time and date. On the Smart Remote Controller, navigate to:  
MENU > SETTINGS > USER PREFERENCES . SET TIME/DATE

Also set the target temperature and humidity for both day and night. From the main menu click on the respective value and use the + and - icons to adjust. Click the sun and moon icons to switch settings for day and night.

The user manual goes further in depth and addresses more options and features.

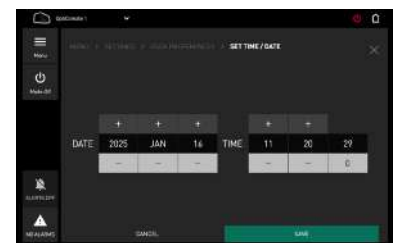

Time and date menu

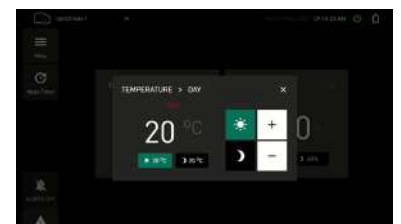

Set target values

## 6. Operating mode

Easiest way of controlling the day/night cycle is to set the operating mode to 'AUTO' which uses the humidity/light sensor to determine if it is day or night. Alternatively you can also set a specific timer or have it run indefinitely in one of the two phases of the cycle. The user manual goes further in depth on these settings. On the main menu click the button below the menu to access this menu.

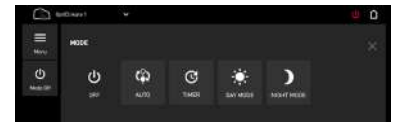

Operating mode menu

### 6.6 INVERTER CONTROLLED - CLOSED LOOP

For systems above 15 kWatts of cooling power, you can install inverters for more precise control over the temperature and a more stable climate overall in your growing area. The advanced setup automates the water flow control and seamlessly and continuously adjusts the pump and the watercooler fan.

When using the advanced setup with inverters, contact your dealer or our professionals at Airlux Technologies for additional support and system design.

The advanced control method differ in a few key area's. Follow these steps.

#### 1. Select correct cable and install an MCD and RCD-B

Check the required cable diameter in the specifications and install the power cable, MCD and RCD-B as described in chapter 6.2. Ask a certified elektrician to install these elements.



Inverter

#### 2. Install the correct power cable using

Use the pass-through to install the open-end power cable to the connection board as described in chapter 6.3. Ask a certified elektrician to install these elements.



SmartBox 8/0

#### 3. Install and connect sensors

In the advanced control setup make sure to have installed the second temperature sensor as instructed in chapter 5.2. Connect the first sensor, the one installed in front of the RevomaxII to the P1 port on the SmartBox 8/0. The port is located in the bottom-left of the Smartbox 8/0. The second temperature sensor goes to P2.



Temperature sensors install sequence

Also connect the humidity/light sensor to the RevomaxII on position 2 as described in chapter 6.1. Route the humidity/light sensor to the growing area and hang half-way between the plant canopy and the fixtures for optimal readings.



Tapsaddle

Last part of this step is the compressor start stop sensor. Connect it to position 4 of the connection board (chapter 6.1). Now lead the communication cable to the Smartbox 8/0 and connect it to the in/out port.

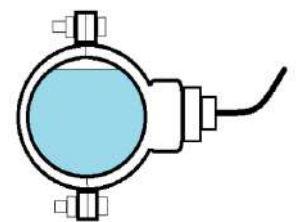

Tapsaddle sideview

#### 4. Pressure sensors

In the advanced setup we also install two pressure sensors on the positions as described in chapter 5.2. Connect the first one (pressure low - in front of the water pump) on P5 and the second one (pressure high) after the water pump) to P6. The pressure sensors can sense a drop in pressure and can automatically shut down the system to prevent damage.



Pressuresensors install sequence



Pressure Sensor

#### 4. Communication cable to Smart Remote Controller

Connect the Smart Remote Controller with the supplied UTP-USB cable as described in chapter 6.4.

### 5. Connecting Smartbox 8/0 to Inverters

The system contains two inverters a 400V 3-phase version for the water pump (inverter 1) and a 230V 1-phase version for the water cooler (inverter 2). Both must be connected using the supplied **BLUE** interlink cable that is labeled on both sides. The cable end labeled **VFD** must be connected to the inverter, the cable end labeled **Smartport** must be connected to the SmartBox.



Custom labeled interlink cable

Connect the 230V water cooler inverter to P3 on the Smartbox and the 400V water pump inverter to P4 on the Smartbox

### 6. Connecting Inverter 1 to water pump

The inverter must be connected to the pump with a custom power cable setup. Pumps must be connected with a 3-phase inverter. Make sure to order a 3-phase pump in this situation. Connect the power cable in the correct manner, as stated below.

- Use a shielded cable in all cases
- Connect ground from pump separately, not with the same cable the pump is powered
- Keep distance between pump and inverter as short as possible, mount indoors

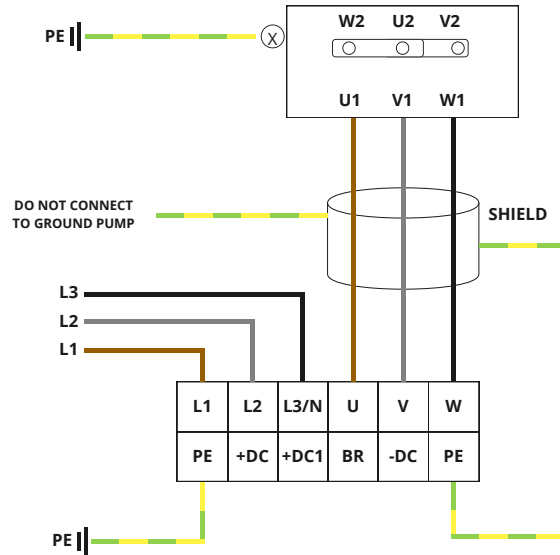

Power schematic inverter to pump

### 7. Connecting Inverter 2 to water cooler fan

The inverters must be connected to the watercooler(fan) with a custom power cable setup. Coolerfan must be connected to a single-phase inverter. Make sure to connect the power cable in the correct manner, as stated below.

- Use a shielded cable in all cases
- Connect ground from pump separately, not with the same cable the pump is powered
- Keep distance between pump and inverter as short as possible, mount indoors

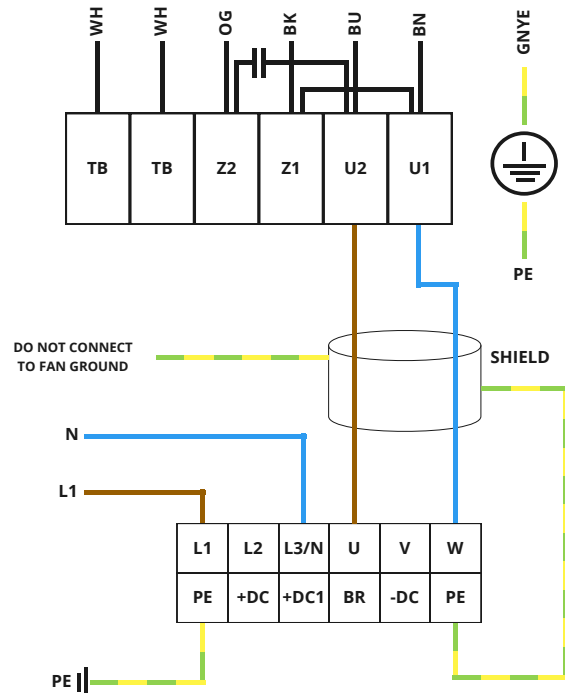

Power schematic inverter to watercooler fan

## Advanced control schematic

The complete control setup must look like the schematic below.

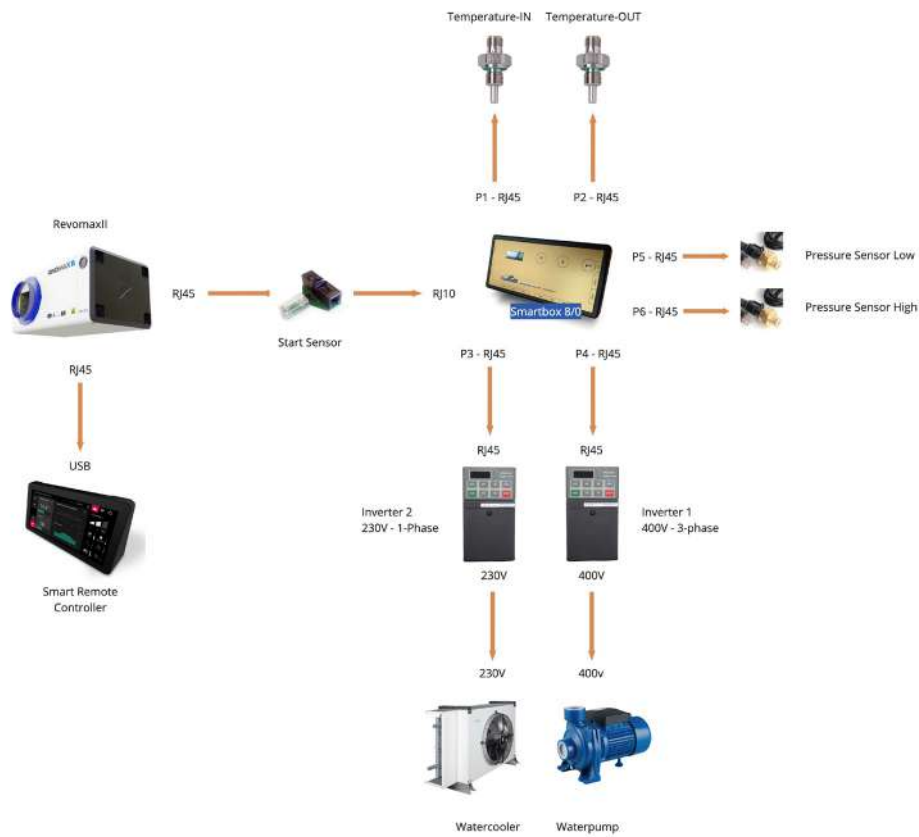

## 6.7 INVERTER CONTROLLED - CLOSED LOOP - FIRST USE

The first use sequence of the inverter controlled setup is the same as the sequence for the basic controlled option (chapter 6.4). Follow the same steps with the exception that the delta temperature is automated. Just skip that step.

# 7. FILLING THE LOOP

## 7.1 GLYCOL

The RevomaxII closed loop systems are compatible with a water-glycol mix. When the system is used in areas that have below zero degrees Celcius temperatures regularly (Winter-time), a Water-Glycol Mix is mandatory to prevent the system from freezing up and corrosion.

For each potential degree Celcius below zero, you need 1% of glycol in your mix. For example, in the Netherlands temperatures rarely, if ever, reach below -15 degrees Celcius. So a safe mix and a bit of headroom a 20% mix is advised.

Add the correct amount of glycol to the system first, then water until static pressure is 1.5 bar (The installed manometer, not the manometer on the RevomaxII unit). In the case the system is already filled with water, drain double the amount of calculated glycol of water first, then add the glycol and re-fill the water until pressurized at 1.5 bar again.

NOTE: on the market you can obtain pure glycol or pre-mixed water-glycol. Make sure to use the correct type. Airlux Technologies strongly recommend PROPYLENE glycol, not ETHYLENE.

## 7.2 FILLING THE LOOP

Note: when the temperature at the cooler location is below zero Celcius, do not fill the system. This can lead to permanent damage to the cooler.

### Steps

1. Check all water connections before filling the loop.
2. Connect water supply to the filling tap
3. Open the air bleeder that is installed on the highest point of the installation
4. Open the water supply and start filling the loop, wait for pressure to build to 1 bar and for all excess air to escape.
5. Make sure the RevomaxII is powered but not turned on. Start the pump with dipswitch 3. (chapter 6.1), Run the RevomaxII for two hours and check for leaks. Check the manometer during the testrun and make sure pressure never drops below 0.5 bar.
6. Disable dipswitch 3 and drain the loop. Collect the water to determine the amount of glycol that needs to be added.
7. Re-fill the loop with the water-glycol mix with a submersible pump
8. Activate the pump again with dipswitch 3 and make sure the system builds up pressure to 1.5 bar on the manometer that is located before the pump.
9. Close the filling tap and remove any water sources and submersive pump. Your system is now filled up correctly.

## 7.3 START USING

Congratulations, your system is now ready to use. Check the respective manuals (RevomaxII or Pro 3/4) for more information on configuring your settings and daily operation.

Find all our manuals and guides at [www.opticlimate.com/nl/knowledge-base](http://www.opticlimate.com/nl/knowledge-base)



Propylene Glycol



Manometer - Check Pressure in Bar



Submersible Pump

## 8. WARRANTY

The Revomax II series and accessories are designed and manufactured with maximum care and craftsmanship. Airlux Technologies warrants the delivered goods to be free of defects for the duration of the applicable warranty period under normal use and conditions after the original purchase date. When the product shows any defects within this period that is not due to improper use, Airlux Technologies will replace or repair the defect product with a suitable replacement with at least the same functionality and specifications. Warranty of the replaced products will remain under warranty for the remaining period from the original product and purchase date. For service, the owner ships the unit to the closest Airlux Technologies service location, to be determined by the service desk. Airlux Technologies will require the original receipt to determine the warranty eligibility.

Contact your dealer for warranty information or find us at [airluxtechnologies.com](http://airluxtechnologies.com)

By Phone: +31 20 776 6006

By e-mail: [support@airluxtechnologies.com](mailto:support@airluxtechnologies.com)



**Direct link:**

<https://www.opticlimat.com/nl/knowledge-base/>

Scan the QR-code to go to our online knowledge base for the latest manuals and information